



# STP/F21NM50N - STW21NM50N STB21NM50N - STB21NM50N-1

N-channel 500V - 0.15Ω - 18A TO-220/FP/D<sup>2</sup>/I<sup>2</sup>PAK/TO-247  
Second generation MDmesh™ Power MOSFET

## General features

Type	V <sub>DSS</sub> (@T <sub>jmax</sub> )	R <sub>DS(on)</sub>	I <sub>D</sub>
STB21NM50N	550V	< 0.19Ω	18A
STB21NM50N-1	550V	< 0.19Ω	18A
STF21NM50N	550V	< 0.19Ω	18A <sup>(1)</sup>
STP21NM50N	550V	< 0.19Ω	18A
STW21NM50N	550V	< 0.19Ω	18A

1. Limited by wire bonding

- 100% avalanche tested
- Low input capacitance and gate charge
- Low gate input resistance

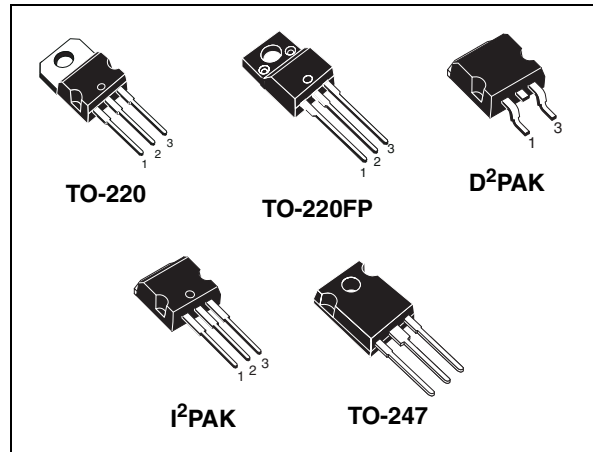

## Description

The devices are realized with the second generation of MDmesh Technology. This revolutionary Power MOSFET associates a new vertical structure to the company's strip layout to yield one of the world's lowest on-resistance and gate charge. It is therefore suitable for the most demanding high efficiency converters

## Applications

- Switching application

## Internal schematic diagram

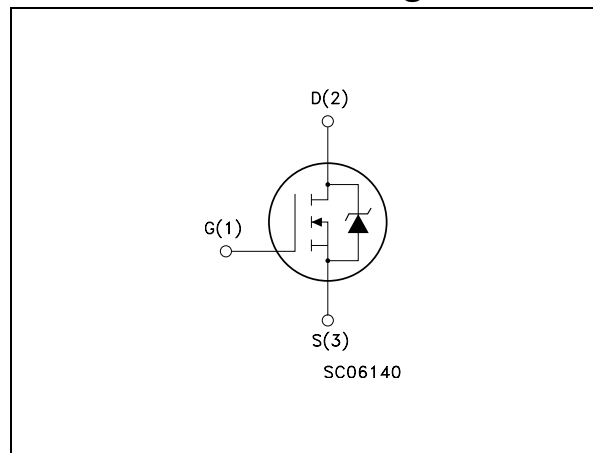

## Order codes

Part number	Marking	Package	Packaging
STB21NM50N	B21NM50N	D <sup>2</sup> PAK	Tape & reel
STB21NM50N-1	B21NM50N	I <sup>2</sup> PAK	Tube
STF21NM50N	F21NM50N	TO-220FP	Tube
STP21NM50N	P21NM50N	TO-220	Tube
STW21NM50N	W21NM50N	TO-247	Tube

## Contents

<b>1</b>	<b>Electrical ratings</b> .....	<b>3</b>
<b>2</b>	<b>Electrical characteristics</b> .....	<b>4</b>
2.1	Electrical characteristics (curves) .....	6
<b>3</b>	<b>Test circuit</b> .....	<b>9</b>
<b>4</b>	<b>Package mechanical data</b> .....	<b>10</b>
<b>5</b>	<b>Packing mechanical data</b> .....	<b>16</b>
<b>6</b>	<b>Revision history</b> .....	<b>17</b>

# 1 Electrical ratings

**Table 1. Absolute maximum ratings**

Symbol	Parameter	Value		Unit
		TO-220/ D <sup>2</sup> PAK/ I <sup>2</sup> PAK/TO-247	TO-220FP	
V <sub>DS</sub>	Drain-source voltage (V <sub>GS</sub> = 0)	500		V
V <sub>GS</sub>	Gate- source voltage	±25		V
I <sub>D</sub>	Drain current (continuous) at T <sub>C</sub> = 25°C	18	18 <sup>(1)</sup>	A
I <sub>D</sub>	Drain current (continuous) at T <sub>C</sub> = 100°C	11	11 <sup>(1)</sup>	A
I <sub>DM</sub> <sup>(2)</sup>	Drain current (pulsed)	72	72 <sup>(1)</sup>	A
P <sub>TOT</sub>	Total dissipation at T <sub>C</sub> = 25°C	140	30	W
	Derating factor	1.12	0.23	W/°C
dv/dt <sup>(3)</sup>	Peak diode recovery voltage slope	15		V/ns
Viso	Insulation withstand voltage (RMS) from all three leads to external heat sink (t=1s;T <sub>C</sub> =25°C)	--	2500	V
T <sub>stg</sub>	Storage temperature	-55 to 150		°C
T <sub>j</sub>	Max. operating junction temperature	150		

- Limited only by maximum temperature allowed
- Pulse width limited by safe operating area
- I<sub>SD</sub> ≤ 18 A, di/dt ≤ 400 A/μs, V<sub>DD</sub> = 80% V<sub>(BR)DSS</sub>

**Table 2. Thermal data**

Symbol	Parameter	TO-220/D <sup>2</sup> PAK/ I <sup>2</sup> PAK / TO-247	TO-220FP	Unit
R <sub>thj-case</sub>	Thermal resistance junction-case max	0.89	4.21	°C/W
R <sub>thj-amb</sub>	Thermal resistance junction-ambient max	62.5		°C/W
T <sub>l</sub>	Maximum lead temperature for soldering purpose	300		°C

**Table 3. Avalanche characteristics**

Symbol	Parameter	Max value	Unit
I <sub>AS</sub>	Avalanche current, repetitive or not-repetitive (pulse width limited by T <sub>j</sub> max)	9	A
E <sub>AS</sub>	Single pulse avalanche energy (starting T <sub>j</sub> = 25°C, I <sub>D</sub> = I <sub>AR</sub> , V <sub>DD</sub> = 50V)	480	mJ

## 2 Electrical characteristics

( $T_{CASE}=25^{\circ}C$  unless otherwise specified)

**Table 4. On/off states**

Symbol	Parameter	Test conditions	Value			Unit
			Min.	Typ.	Max.	
$V_{(BR)DSS}$	Drain-source breakdown voltage	$I_D = 1mA, V_{GS} = 0$	500			V
$dv/dt^{(1)}$	Drain source voltage slope	$V_{DD}=400V, I_D=25A, V_{GS}=10V$	44			V/ns
$I_{DSS}$	Zero gate voltage drain current ( $V_{GS} = 0$ )	$V_{DS} = \text{Max rating}$ $V_{DS} = \text{Max rating}, T_C @ 125^{\circ}C$			1 10	$\mu A$ $\mu A$
$I_{GSS}$	Gate-body leakage current ( $V_{DS} = 0$ )	$V_{GS} = \pm 20V$			100	nA
$V_{GS(th)}$	Gate threshold voltage	$V_{DS} = V_{GS}, I_D = 250\mu A$	2	3	4	V
$R_{DS(on)}$	Static drain-source on resistance	$V_{GS} = 10V, I_D = 9A$		0.150	0.190	$\Omega$

1. Characteristic value at turn off on inductive load

**Table 5. Dynamic**

Symbol	Parameter	Test conditions	Min.	Typ.	Max.	Unit
$g_{fs}^{(1)}$	Forward transconductance	$V_{DS} = 15V, I_D = 9A$		12		S
$C_{iss}$ $C_{oss}$ $C_{rss}$	Input capacitance Output capacitance Reverse transfer capacitance	$V_{DS} = 25V, f = 1 \text{ MHz}, V_{GS} = 0$		1950 420 60		pF pF pF
$C_{oss \text{ eq.}}^{(2)}$	Equivalent output capacitance	$V_{GS} = 0V, V_{DS} = 0V \text{ to } 400V$		270		pF
$t_{d(on)}$ $t_r$ $t_{d(off)}$ $t_f$	Turn-on delay time Rise time Turn-off delay time Fall time	$V_{DD} = 250V, I_D = 9A$ $R_G = 4.7\Omega, V_{GS} = 10V$ (see <a href="#">Figure 15.</a> )		22 18 90 30		ns ns ns ns
$Q_g$ $Q_{gs}$ $Q_{gd}$	Total gate charge Gate-source charge Gate-drain charge	$V_{DD} = 400V, I_D = 18A,$ $V_{GS} = 10V,$ (see <a href="#">Figure 16.</a> )		65 10 30		nC nC nC
$R_g$	Gate input resistance	$f=1\text{MHz}$ Gate DC Bias=0 test signal level=20mV open drain		1.6		$\Omega$

1. Pulsed: pulse duration=300 $\mu s$ , duty cycle 1.5%

2.  $C_{oss \text{ eq.}}$  is defined as a constant equivalent capacitance giving the same charging time as  $C_{oss}$  when  $V_{DS}$  increases from 0 to 80%  $V_{DSS}$

**Table 6. Source drain diode**

Symbol	Parameter	Test conditions	Min.	Typ.	Max.	Unit
$I_{SD}$	Source-drain current				18	A
$I_{SDM}^{(1)}$	Source-drain current (pulsed)				72	A
$V_{SD}^{(2)}$	Forward on voltage	$I_{SD} = 18A, V_{GS} = 0$			1.5	V
$t_{rr}$	Reverse recovery time	$I_{SD} = 18A,$ $di/dt=100A/\mu s$ $V_{DD} = 100V,$ (see <a href="#">Figure 17.</a> )		360		ns
$Q_{rr}$	Reverse recovery charge			5		$\mu C$
$I_{RRM}$	Reverse recovery current			27		A
$t_{rr}$	Reverse recovery time	$I_{SD} = 18A,$ $di/dt=100A/\mu s$ $V_{DD} = 100V, T_j = 150^\circ C$ (see <a href="#">Figure 17.</a> )		464		ns
$Q_{rr}$	Reverse recovery charge			6.5		$\mu C$
$I_{RRM}$	Reverse recovery current			27		A

1. Pulse width limited by safe operating area
2. Pulsed: Pulse duration = 300  $\mu s$ , duty cycle 1.5 %.

## 2.1 Electrical characteristics (curves)

Figure 1. Safe operating area

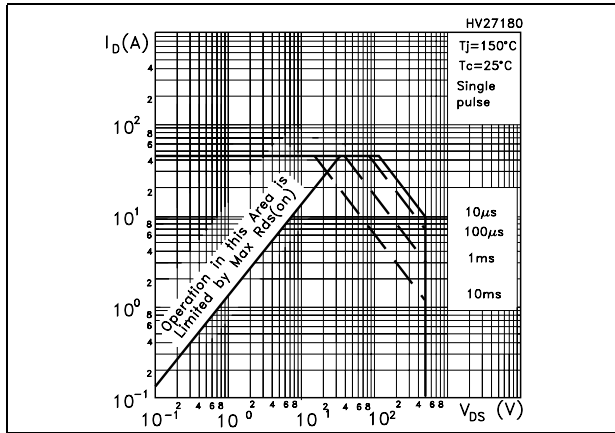

Figure 2. Thermal impedance

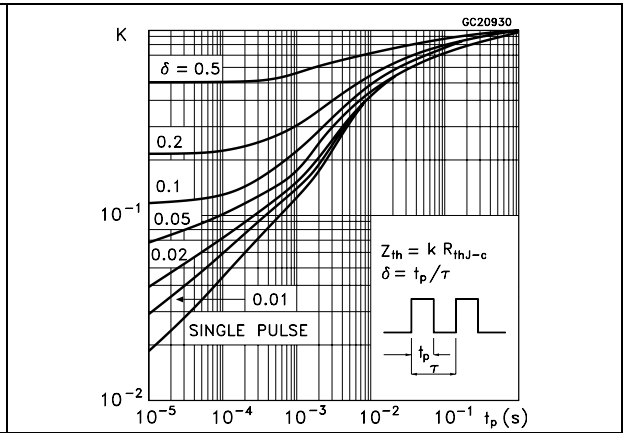

Figure 3. Safe operating area for TO-220FP

Figure 4. Thermal impedance for TO-220FP

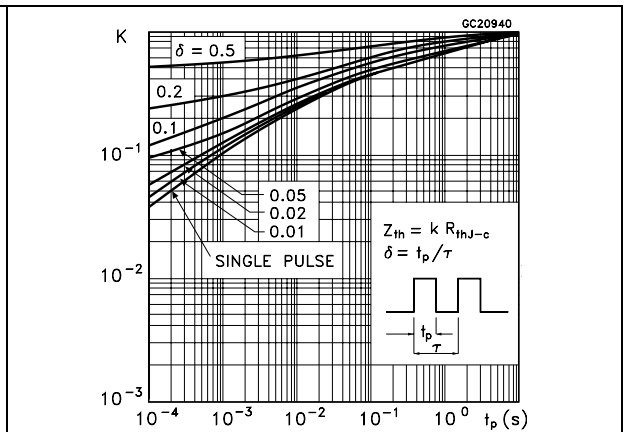
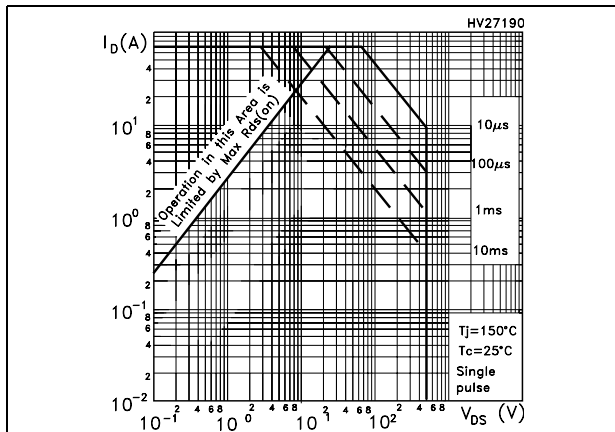

Figure 5. Output characteristics

Figure 6. Transfer characteristics

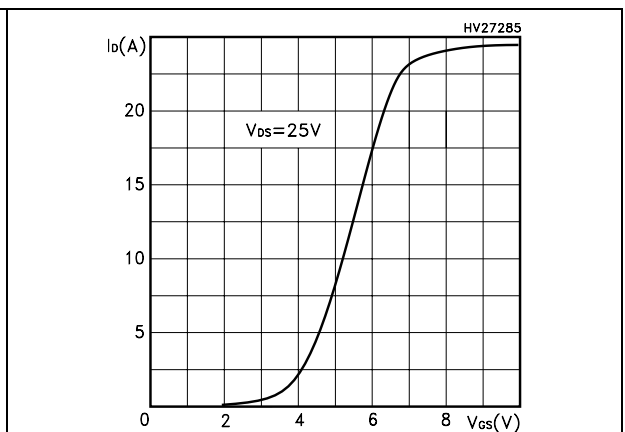
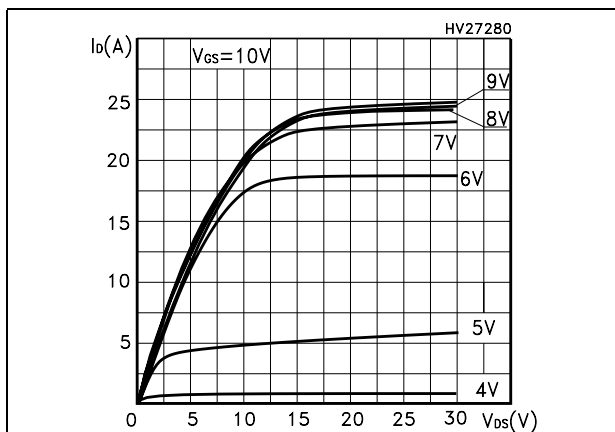

Figure 7. Transconductance

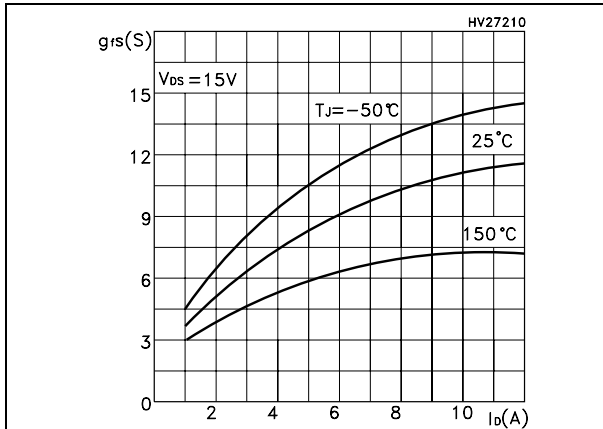

Figure 8. Static drain-source on resistance

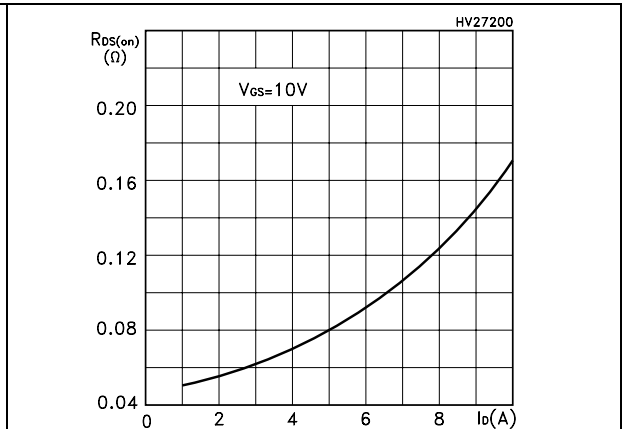

Figure 9. Gate charge vs gate-source voltage

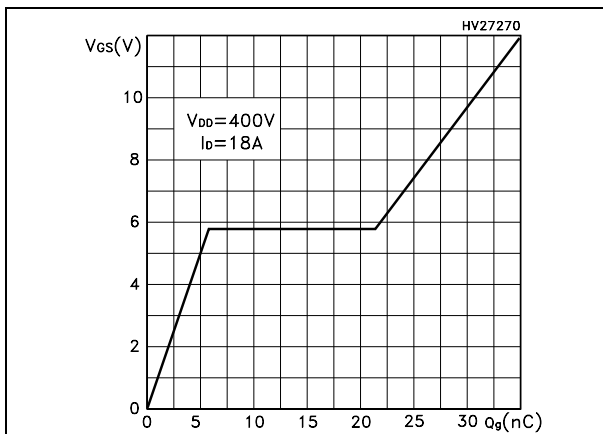

Figure 10. Capacitance variations

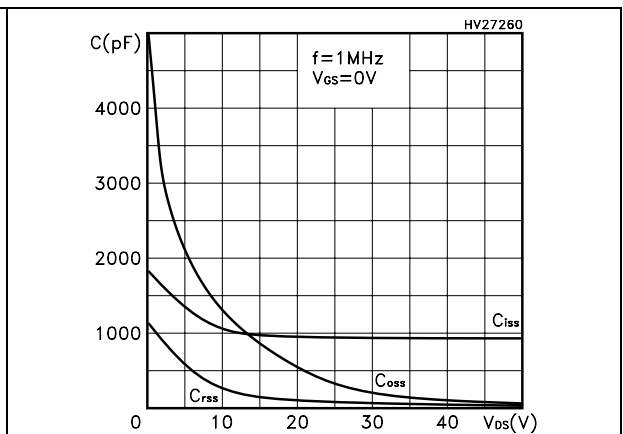

Figure 11. Normalized gate threshold voltage vs temperature

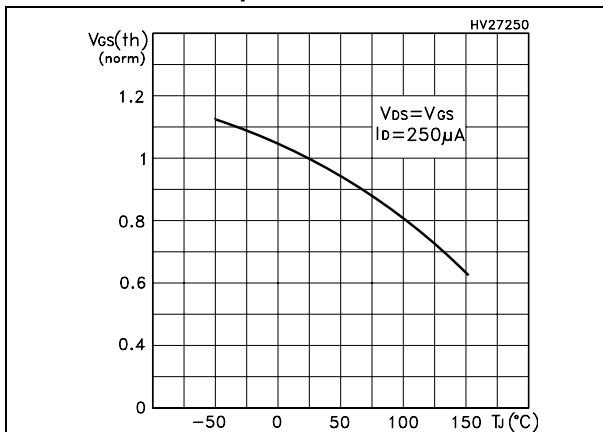

Figure 12. Normalized on resistance vs temperature

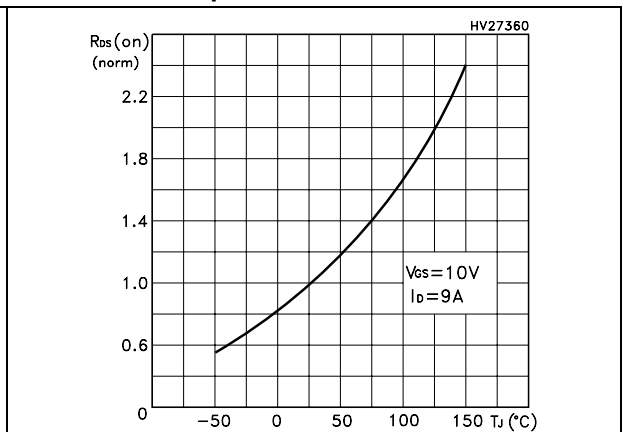

Figure 13. Source-drain diode forward characteristics

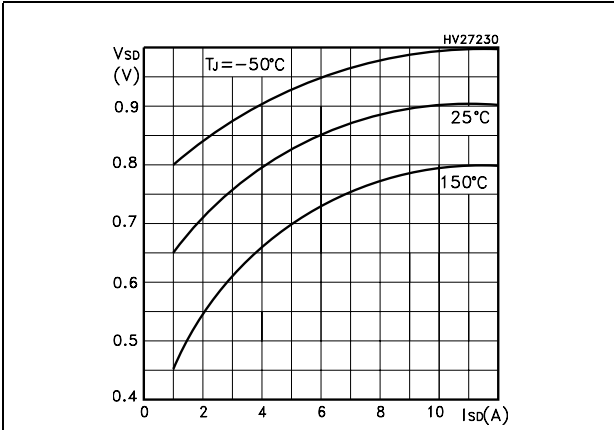
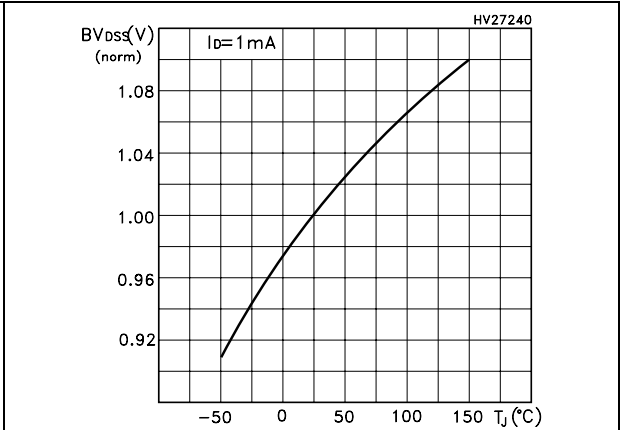

Figure 14. Normalized  $BV_{DSS}$  vs temperature





### 3 Test circuit

**Figure 15. Switching times test circuit for resistive load**

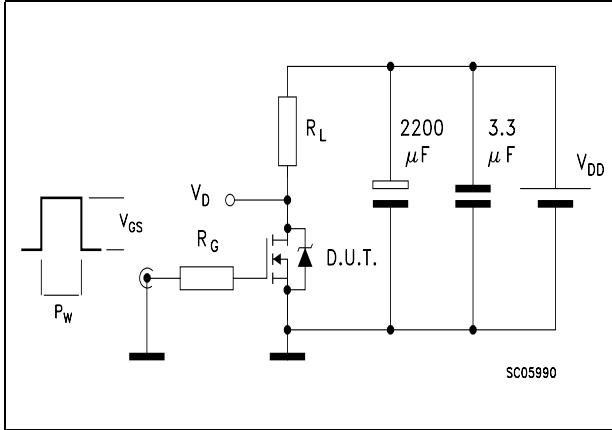

**Figure 16. Gate charge test circuit**

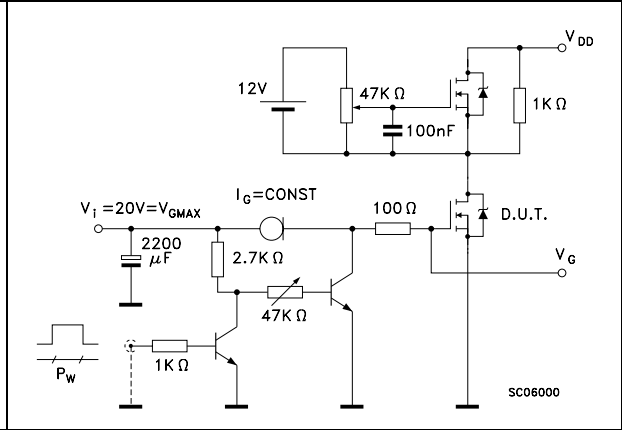

**Figure 17. Test circuit for inductive load switching and diode recovery times**

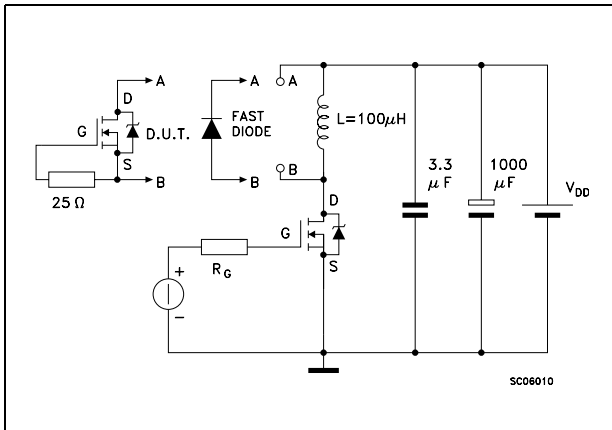

**Figure 18. Unclamped Inductive load test circuit**

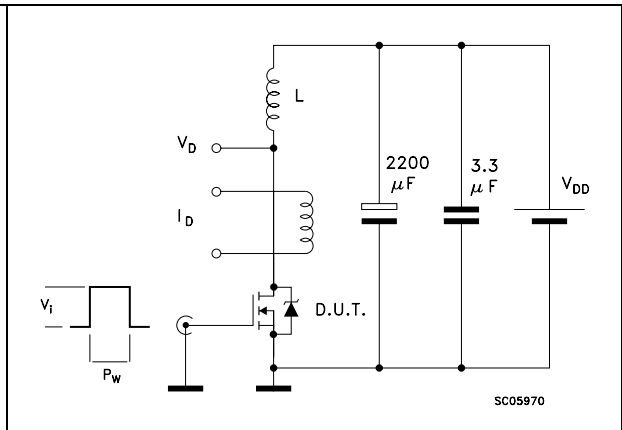

**Figure 19. Unclamped inductive waveform**

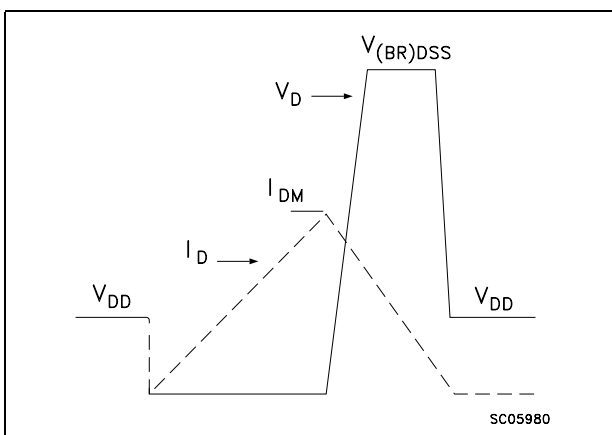

**Figure 20. Switching time waveform**

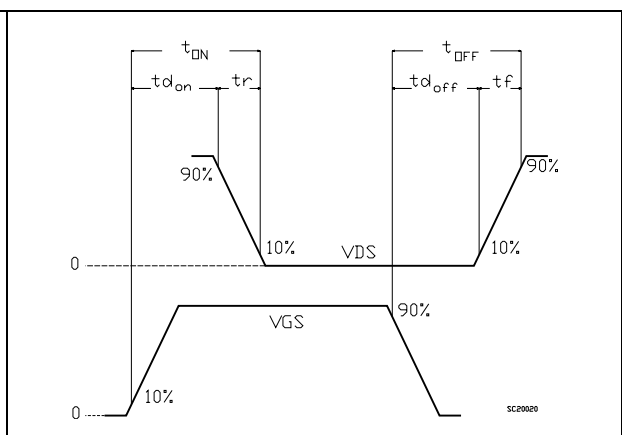

## 4 Package mechanical data

In order to meet environmental requirements, ST offers these devices in ECOPACK® packages. These packages have a Lead-free second level interconnect . The category of second level interconnect is marked on the package and on the inner box label, in compliance with JEDEC Standard JESD97. The maximum ratings related to soldering conditions are also marked on the inner box label. ECOPACK is an ST trademark. ECOPACK specifications are available at: [www.st.com](http://www.st.com)

**TO-220 MECHANICAL DATA**

DIM.	mm.			inch		
	MIN.	TYP.	MAX.	MIN.	TYP.	MAX.
A	4.40		4.60	0.173		0.181
b	0.61		0.88	0.024		0.034
b1	1.15		1.70	0.045		0.066
c	0.49		0.70	0.019		0.027
D	15.25		15.75	0.60		0.620
E	10		10.40	0.393		0.409
e	2.40		2.70	0.094		0.106
e1	4.95		5.15	0.194		0.202
F	1.23		1.32	0.048		0.052
H1	6.20		6.60	0.244		0.256
J1	2.40		2.72	0.094		0.107
L	13		14	0.511		0.551
L1	3.50		3.93	0.137		0.154
L20		16.40			0.645	
L30		28.90			1.137	
øP	3.75		3.85	0.147		0.151
Q	2.65		2.95	0.104		0.116

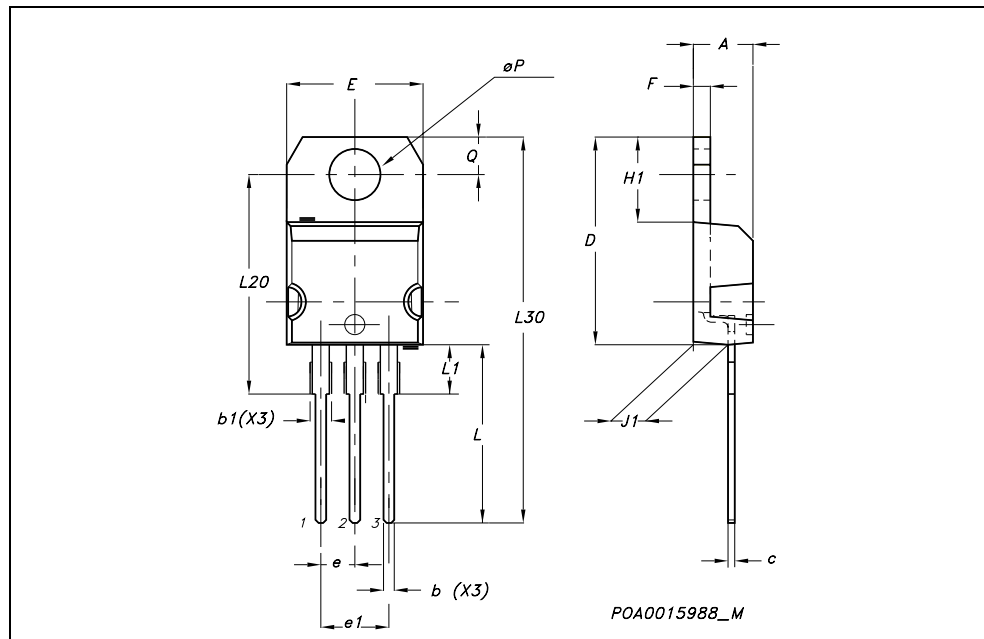

**TO-220FP MECHANICAL DATA**

DIM.	mm.			inch		
	MIN.	TYP	MAX.	MIN.	TYP.	MAX.
A	4.4		4.6	0.173		0.181
B	2.5		2.7	0.098		0.106
D	2.5		2.75	0.098		0.108
E	0.45		0.7	0.017		0.027
F	0.75		1	0.030		0.039
F1	1.15		1.7	0.045		0.067
F2	1.15		1.7	0.045		0.067
G	4.95		5.2	0.195		0.204
G1	2.4		2.7	0.094		0.106
H	10		10.4	0.393		0.409
L2		16			0.630	
L3	28.6		30.6	1.126		1.204
L4	9.8		10.6	.0385		0.417
L5	2.9		3.6	0.114		0.141
L6	15.9		16.4	0.626		0.645
L7	9		9.3	0.354		0.366
Ø	3		3.2	0.118		0.126



**TO-262 (I<sup>2</sup>PAK) MECHANICAL DATA**

DIM.	mm.			inch		
	MIN.	TYP.	MAX.	MIN.	TYP.	MAX.
A	4.40		4.60	0.173		0.181
A1	2.40		2.72	0.094		0.107
b	0.61		0.88	0.024		0.034
b1	1.14		1.70	0.044		0.066
c	0.49		0.70	0.019		0.027
c2	1.23		1.32	0.048		0.052
D	8.95		9.35	0.352		0.368
e	2.40		2.70	0.094		0.106
e1	4.95		5.15	0.194		0.202
E	10		10.40	0.393		0.410
L	13		14	0.511		0.551
L1	3.50		3.93	0.137		0.154
L2	1.27		1.40	0.050		0.055

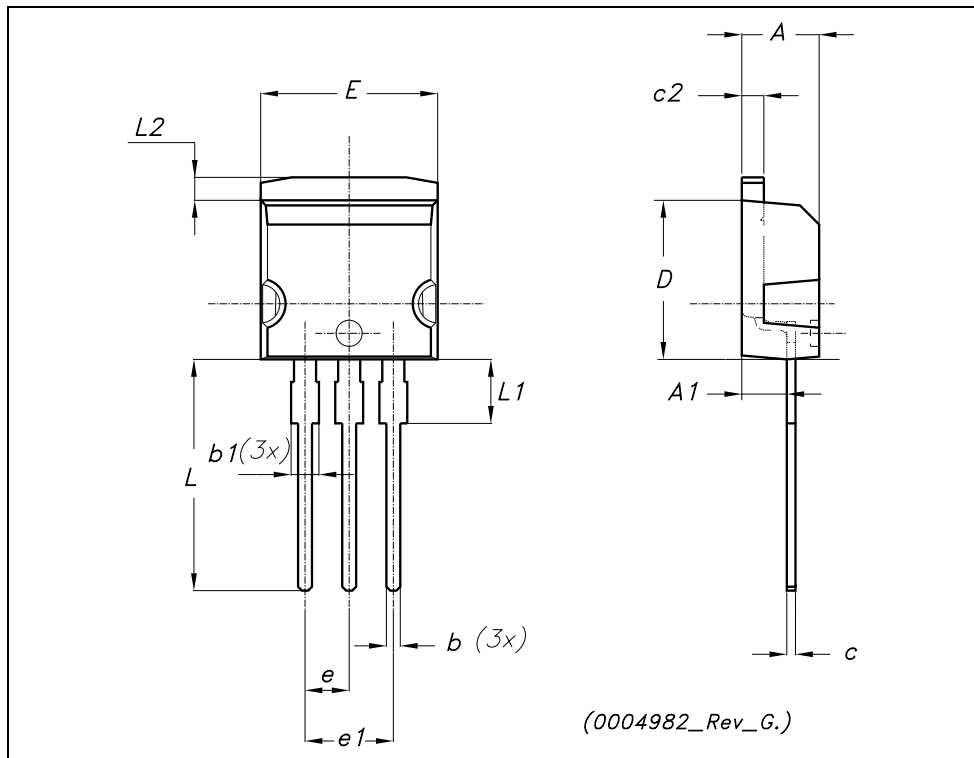

**D<sup>2</sup>PAK MECHANICAL DATA**

DIM.	mm.			inch		
	MIN.	TYP	MAX.	MIN.	TYP.	MAX.
A	4.4		4.6	0.173		0.181
A1	2.49		2.69	0.098		0.106
A2	0.03		0.23	0.001		0.009
B	0.7		0.93	0.027		0.036
B2	1.14		1.7	0.044		0.067
C	0.45		0.6	0.017		0.023
C2	1.23		1.36	0.048		0.053
D	8.95		9.35	0.352		0.368
D1		8			0.315	
E	10		10.4	0.393		
E1		8.5			0.334	
G	4.88		5.28	0.192		0.208
L	15		15.85	0.590		0.625
L2	1.27		1.4	0.050		0.055
L3	1.4		1.75	0.055		0.068
M	2.4		3.2	0.094		0.126
R		0.4			0.015	
V2	0°		4°			



**TO-247 MECHANICAL DATA**

DIM.	mm.			inch		
	MIN.	TYP	MAX.	MIN.	TYP.	MAX.
A	4.85		5.15	0.19		0.20
A1	2.20		2.60	0.086		0.102
b	1.0		1.40	0.039		0.055
b1	2.0		2.40	0.079		0.094
b2	3.0		3.40	0.118		0.134
c	0.40		0.80	0.015		0.03
D	19.85		20.15	0.781		0.793
E	15.45		15.75	0.608		0.620
e		5.45			0.214	
L	14.20		14.80	0.560		0.582
L1	3.70		4.30	0.14		0.17
L2		18.50			0.728	
øP	3.55		3.65	0.140		0.143
øR	4.50		5.50	0.177		0.216
S		5.50			0.216	

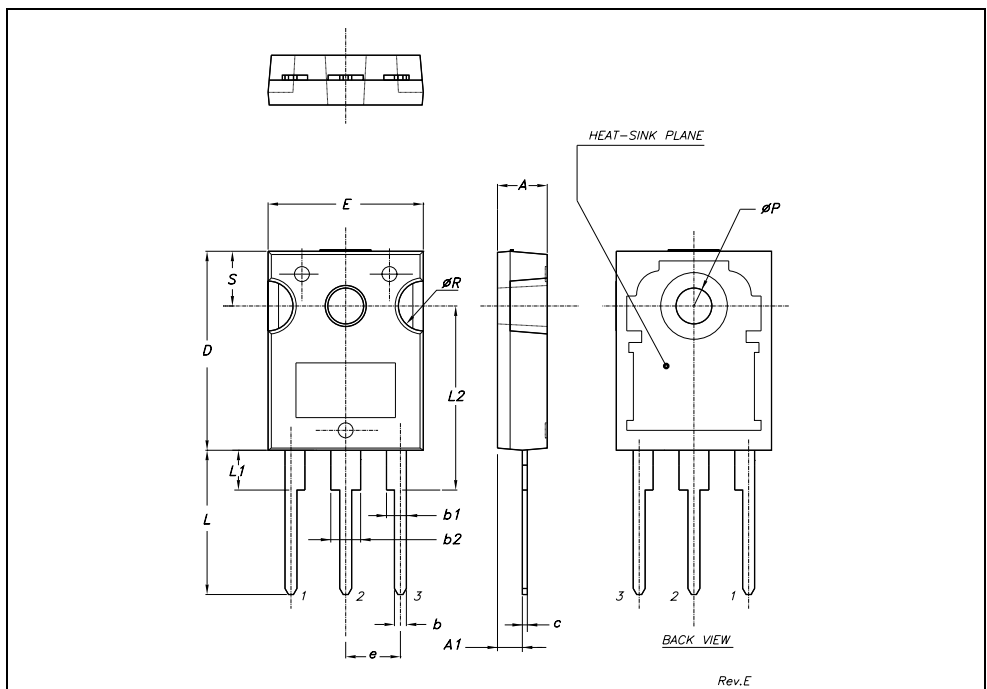

# 5 Packing mechanical data

## D<sup>2</sup>PAK FOOTPRINT

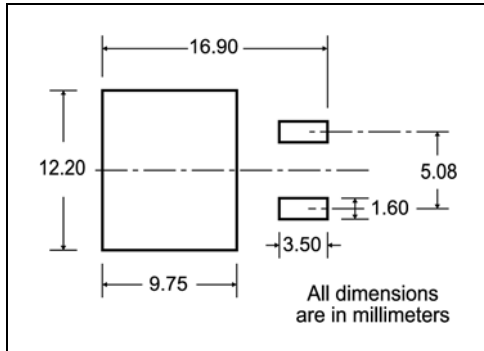

## TAPE AND REEL SHIPMENT

**TAPE MECHANICAL DATA**

DIM.	mm		inch	
	MIN.	MAX.	MIN.	MAX.
A0	10.5	10.7	0.413	0.421
B0	15.7	15.9	0.618	0.626
D	1.5	1.6	0.059	0.063
D1	1.59	1.61	0.062	0.063
E	1.65	1.85	0.065	0.073
F	11.4	11.6	0.449	0.456
K0	4.8	5.0	0.189	0.197
P0	3.9	4.1	0.153	0.161
P1	11.9	12.1	0.468	0.476
P2	1.9	2.1	0.075	0.082
R	50		1.574	
T	0.25	0.35	0.0098	0.0137
W	23.7	24.3	0.933	0.956

**REEL MECHANICAL DATA**

DIM.	mm		inch	
	MIN.	MAX.	MIN.	MAX.
A		330		12.992
B	1.5		0.059	
C	12.8	13.2	0.504	0.520
D	20.2		0.795	
G	24.4	26.4	0.960	1.039
N	100		3.937	
T		30.4		1.197

BASE QTY	BULK QTY
1000	1000

10 pitches cumulative tolerance on tape +/- 0.2 mm

Center line of cavity

User Direction of Feed

FEED DIRECTION

Bending radius

\* on sales type



## 6 Revision history

Table 7. Revision history

Date	Revision	Changes
29-Sep-2005	1	First release
05-Oct-2005	2	Symbol changed on <i>Dynamic</i>
19-Oct-2005	3	Changed <i>Figure 8: Static drain-source on resistance</i>
29-Nov-2005	4	Modified <i>Figure 5: Output characteristics</i>
20-Nov-2006	5	Modified <i>Figure 8: Static drain-source on resistance</i>
19-Jan-2007	6	Typo mistake on <i>Table 5</i> .

**Please Read Carefully:**

Information in this document is provided solely in connection with ST products. STMicroelectronics NV and its subsidiaries ("ST") reserve the right to make changes, corrections, modifications or improvements, to this document, and the products and services described herein at any time, without notice.

All ST products are sold pursuant to ST's terms and conditions of sale.

Purchasers are solely responsible for the choice, selection and use of the ST products and services described herein, and ST assumes no liability whatsoever relating to the choice, selection or use of the ST products and services described herein.

No license, express or implied, by estoppel or otherwise, to any intellectual property rights is granted under this document. If any part of this document refers to any third party products or services it shall not be deemed a license grant by ST for the use of such third party products or services, or any intellectual property contained therein or considered as a warranty covering the use in any manner whatsoever of such third party products or services or any intellectual property contained therein.

**UNLESS OTHERWISE SET FORTH IN ST'S TERMS AND CONDITIONS OF SALE ST DISCLAIMS ANY EXPRESS OR IMPLIED WARRANTY WITH RESPECT TO THE USE AND/OR SALE OF ST PRODUCTS INCLUDING WITHOUT LIMITATION IMPLIED WARRANTIES OF MERCHANTABILITY, FITNESS FOR A PARTICULAR PURPOSE (AND THEIR EQUIVALENTS UNDER THE LAWS OF ANY JURISDICTION), OR INFRINGEMENT OF ANY PATENT, COPYRIGHT OR OTHER INTELLECTUAL PROPERTY RIGHT.**

**UNLESS EXPRESSLY APPROVED IN WRITING BY AN AUTHORIZED ST REPRESENTATIVE, ST PRODUCTS ARE NOT RECOMMENDED, AUTHORIZED OR WARRANTED FOR USE IN MILITARY, AIR CRAFT, SPACE, LIFE SAVING, OR LIFE SUSTAINING APPLICATIONS, NOR IN PRODUCTS OR SYSTEMS WHERE FAILURE OR MALFUNCTION MAY RESULT IN PERSONAL INJURY, DEATH, OR SEVERE PROPERTY OR ENVIRONMENTAL DAMAGE. ST PRODUCTS WHICH ARE NOT SPECIFIED AS "AUTOMOTIVE GRADE" MAY ONLY BE USED IN AUTOMOTIVE APPLICATIONS AT USER'S OWN RISK.**

Resale of ST products with provisions different from the statements and/or technical features set forth in this document shall immediately void any warranty granted by ST for the ST product or service described herein and shall not create or extend in any manner whatsoever, any liability of ST.

ST and the ST logo are trademarks or registered trademarks of ST in various countries.

Information in this document supersedes and replaces all information previously supplied.

The ST logo is a registered trademark of STMicroelectronics. All other names are the property of their respective owners.

© 2007 STMicroelectronics - All rights reserved

STMicroelectronics group of companies

Australia - Belgium - Brazil - Canada - China - Czech Republic - Finland - France - Germany - Hong Kong - India - Israel - Italy - Japan - Malaysia - Malta - Morocco - Singapore - Spain - Sweden - Switzerland - United Kingdom - United States of America

[www.st.com](http://www.st.com)